

AQUARAY® SMP-DW/PW

UV Systems

UV

The Aquaray® SMP-DW/PW range offers compact and high efficiency system for small and medium water plant with a range of flow rates from 22 to 440m³/h with exceptional reliability and ease of operation.

APPLICATIONS

- Drinking water
- Process water
- Aquaculture
- Deozonation
- Toc Reduction
- Ballast water
- Cooling water
- Advanced oxidation

MAIN CHARACTERISTICS

- Multi emission medium pressure Lamp
- Power step regulation
- Simple control logic

MAIN FEATURES

- Polychromatic medium pressure lamps for highest germicidal efficiency
- Fewer lamps
- Easy to install in new or existing water plants
- User friendly operator interface microprocessor controlled
- Data logging for up to one year

UV TECHNOLOGY : SMP-DW/PW

The Aquaray® SMP-DW/PW units have been designed to disinfect potable or process water. The germicidal effect of the UV light inactivates most micro-organisms such as bacteria, viruses and parasites. UV is known to be particularly efficient to inactivate *Cryptosporidium Parvum* and *Giardia Lamblia*.

The medium pressure lamps have an action on nucleic acid and proteins for micro-organisms inactivation. The UV dose (UV intensity x contact time) defines the treatment efficiency which is provided by the unit. The effective dose applied depends on the UV transmittance of water to be treated as well as the proper hydraulic design of the unit.

HOW IT WORKS

The medium pressure lamps are powered by magnetic ballasts. The lamps are inserted in pure quartz sleeves isolating them from the water. The lamps can be easily changed when indicated by the micro-processor control unit.

A UV sensor is installed to monitor UV radiation. An optimal wiper system is available for cleaning the UV lamp quartz sleeve.



PRODUCT HIGHLIGHTS

- > Polychromatic medium pressure lamp
- > User friendly operator interface
- > Fewer lamps
- > Automatic mechanical wiper

TECHNICAL DATA SMP-DW/PW Model	Flow Rate ⁽¹⁾ (m ³ /h)	Total Lamp Power (kW)	Reactor (mm)													In-Out	Control Panel: L x H x W (mm)
			A	B	C	D	E	F	G	H	J	K	L	M	N		
SMP 100-75-1/2	22	1.5	100	125	700	145	1065	175	900	700	70	100	100	350	285	DN 80	600 x 600 x 210
SMP 100-75-1	44	3	100	125	700	145	1065	175	900	700	70	100	100	350	285	DN 80	600 x 600 x 210
SMP 150-100-1	79	3	150	150	650	170	1065	225	900	700	120	150	125	350	285	DN 100	600 x 600 x 210
SMP 200-150-1	109	3	200	175	600	195	1065	275	900	700	170	200	150	350	285	DN 150	600 x 600 x 210
SMP 250-150-1	136	3	250	200	600	195	325	325	900	1000	220	250	175	350	285	DN 150	600 x 600 x 210
SMP 250-200-1	272	6	250	200	600	220	375	325	1250	1000	220	250	175	350	285	DN 200	800 x 1200 x 300
SMP 300-250-1	319	6	300	250	900	220	425	375	1250	1000	270	300	200	350	285	DN 250	800 x 1200 x 300
SMP 300-250-2	440	12	300	250	900	220	650	375	1250	1000	270	300	200	350	285	DN 250	800 x 1200 x 500

Size connection flanges confirmed with proposal

(1) Based on 40 mJ/cm² UV dose at 95% UV transmittance

TECHNICAL FEATURES

- Flanges: BS 4504 (PN10), or ANSI 150
- Reactor Pressure Rating: 10 barg
- Main Power Supply: 400-480V/3ph/50-60 Hz
- Panel Rating: IP54
- Conformity: CE

MATERIALS

- Reactor material: 316L stainless steel/quartz sleeve/silicon O-ring
- Panel material: polyester coated mild steel

OPTIONS

- Automatic wiper
- Power step regulation
- Stainless steel panel
- Triclamp
- Welded reactor surfaces (0.35 µm) and electropolished

REMOTE CONTROL AND ALARMS

- Digital Inputs: lamp start-stop, water flow interlock
- Digital Outputs: system status, pre-alarm, alarm
- Analogue Output: remote indication of UV intensity

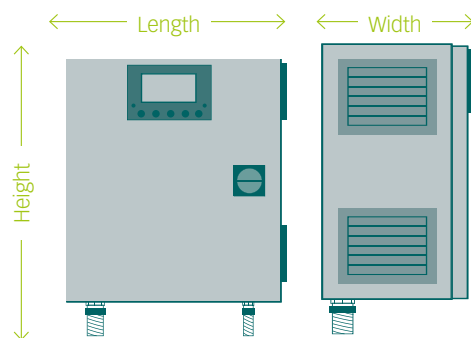
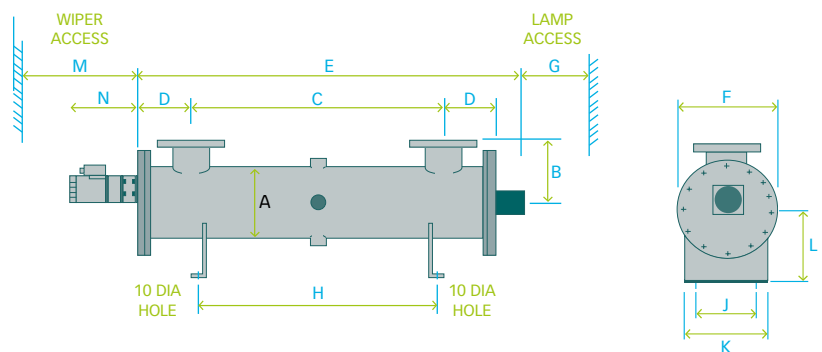

CONTACT

TRIOGEN Ltd
 Unit 14 Langlands Place
 East Kilbride G75 0YF
 Scotland, United Kingdom
 Tel: + 44 (0) 13 55 220 598
 Fax: + 44 (0) 13 55 570 058
 www.triogen.com
 info@triogen.com

Your local distributor: