

The Aquaray® LP range offers compact and high efficiency system for small water plants with a range of flow rates from 10 to 40m³/h with exceptional reliability and ease of operation.

APPLICATIONS

- Drinking water
- Process water
- Aquaculture
- Deozonation
- Cooling water

MAIN CHARACTERISTICS

- Low Pressure High Output Amalgam Lamp

MAIN FEATURES

- High efficiency low pressure lamp amalgam
- Lamp life of 16,000 h
- Horizontal or vertical reactor mounting
- Easy to install in new or existing installations
- Small size suits installations with limited room space
- User friendly operator interface microprocessor controlled

UV TECHNOLOGY : LP

The Aquaray® LP units have been designed to disinfect potable or process water. The germicidal effect of the UV light inactivates most micro-organisms such as bacteria, viruses and parasites. UV is known to be particularly efficient to inactivate *Cryptosporidium Parvum* and *Giardia Lambli*a.

The UV dose (UV Intensity x contact time) defines the treatment efficiency which is provided by the unit. The effective dose applied depends on the UV transmittance of water to be treated as well as the proper hydraulic design of the unit.

HOW IT WORKS

The low pressure amalgam lamps are powered by electronic ballasts. The lamps are inserted in pure quartz sleeves isolating them from the water.

The lamps can be easily changed when required. A UV sensor is available as an option to monitor UV radiation.



PRODUCT HIGHLIGHTS

- > Lamp life of 16,000 h
- > User friendly operator interface
- > Horizontal or vertical reactor mounting

TECHNICAL DATA LP MODEL	Flow Rate ⁽¹⁾ (m ³ /h)	Lamp Power (kW)	Reactor Dimensions (mm)					In - Out	Control Panel: L x H x W (mm)
			A	B	C	D	E		
LP 100-40-120-1	9	0.120	100	950	60	830	100	DN 40	300 x 300 x 150
LP 150-50-120-1	11	0.120	154	950	100	750	125	DN 50	400 x 600 x 200
LP 150-50-120-2	20	0.240	154	950	100	750	125	DN 50	400 x 600 x 200
LP 150-75-120-3	30	0.360	154	950	100	750	125	DN 80	400 x 600 x 200
LP 150-75-120-4	40	0.480	154	950	100	750	125	DN 80	400 x 600 x 200

(1) Based on 40 mJ/cm² UV dose at 95% UV transmittance

TECHNICAL FEATURES

- Flanges: BS 4504 (PN10) or ANSI 150
- Reactor Pressure Rating: 10 barg
- Main Power Supply: 220-240V/1ph/50-60 Hz
- Panel Rating: IP54
- Conformity: CE

MATERIALS

- Reactor material: 316L stainless steel/quartz sleeve / silicon O-ring
- Panel material: mild steel epoxy painted

OPTIONS

- Stainless steel panel
- UV sensor (only LP 150)

REMOTE CONTROL AND ALARMS

- Digital inputs: lamp start-stop, waterflow interlock
- Digital outputs: system status, pre-alarm, system faults

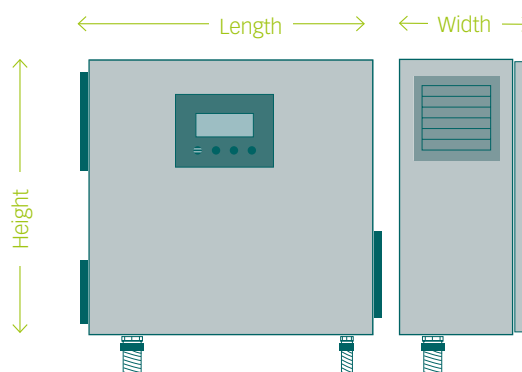
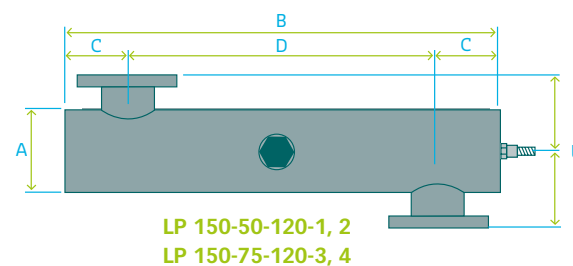
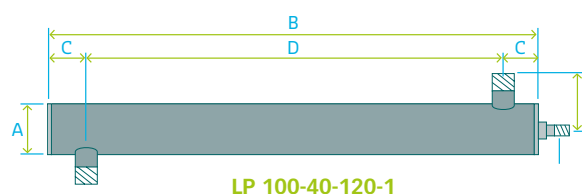

CONTACT

TRIOGEN Ltd
 Unit 14 Langlands Place
 East Kilbride G75 0YF
 Scotland, United Kingdom
 Tel: + 44 (0) 13 55 220 598
 Fax: + 44 (0) 13 55 570 058
 www.triogen.com
 info@triogen.com

Your local distributor: